

LUX M1



MOTOR Kubota Z482 | ENFRIADO POR AGUA
2 CILINDROS
3,600 rpm



MASTIL TELESCOPICO VERTICAL
ALTURA MAXIMA 8.5 m
GARANTIA DE POR VIDA



GENERADOR: 6 kVA — 230 V
60 Hz



CONSUMO DE COMBUSTIBLE: 1.7 l/h
50 HORAS DE RENDIMIENTO



4 x 1,000 W HALURO METALICO
ÁREA ILUMINADA 4,200 m²



MASTIL GIRATORIO A 340°
LAMPARAS AJUSTABLES



ESTRUCTURA DE METAL
GALVANIZADO RECUBRIMIENTO
CON POLVO DE POLIESTER
QUE EVITA LA CORROSION

MADE IN
ITALY



SERIE LM

LUXTOWER 
lighting towers

Serie LM

LUX M1

DATOS TÉCNICOS

Dimensiones y peso

| | | |
|----------------------------|----|--------------------|
| Dimensiones min. | mm | 2560 X 1380 X 2580 |
| Dimensiones max. | mm | 2560 X 2550 X 8500 |
| Peso total sin combustible | Kg | 758 |

Características

| | | |
|-----------------------|------|--------------|
| Rotación | | 340° |
| Focos | W | 4 X 1000 W |
| Lámparas | | METAL HALIDE |
| Estabilidad al viento | Km/h | 80 Km/h |

Generador

| | | |
|---------------------|-------|-------------------------|
| Modelo | | Synchronous Linz Alumen |
| Frecuencia | Hz | 60 |
| Grado de protección | | IP23 |
| Potencia | kVA/V | 6 - 230 |

Motor

| | | |
|---------------------------------|----------------|--|
| Modelo | | Kubota Z482 / 2 cil /enfriado por agua |
| Combustible | | Diesel |
| r.p.m. | | 3,600 |
| Nivel de ruido | db at 7 meters | 65 |
| Capacidad tanque de combustible | l | 80 |
| Horas de funcionamiento | h | 50 |
| Consumo de combustible | l/h | 1.7 |

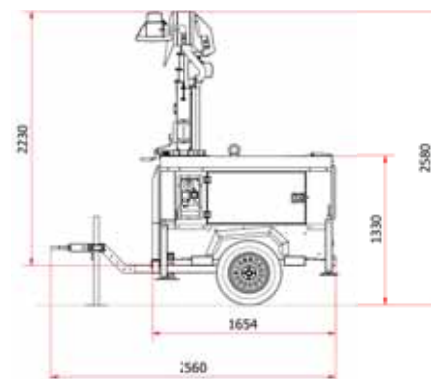
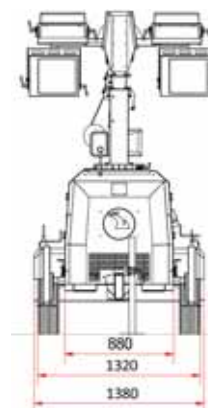

Área iluminada // 5 lux min

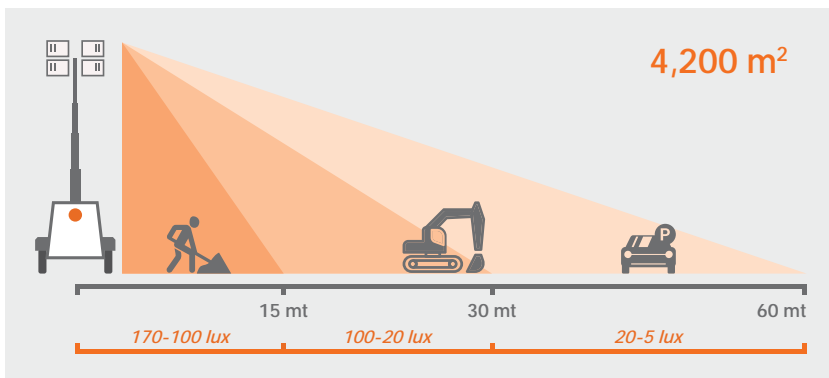

Carga por contenedor y camión



40' Contenedor 14 pzas.
20' Contenedor 6 pzas.



Camión Armada 8 pzas.
Desarmada 14 pzas.

LUXTOWER
lighting towers